



DOBLADORA DE MARRAQUETAS

CARACTERISTICAS

Corriente eléctrica	220/1/50 ó 380/3/50
Producción horaria	2700 piezas
Estructura	Acero Inoxidable o fierro zincado
Potencia motor	0.33 Hp
Consumo	0.25 Kw

MEDIDAS

A	B	C
450mm	1380mm	870mm



Ficha Técnica

Dobladora de Marraquetas

VISTA GENERAL

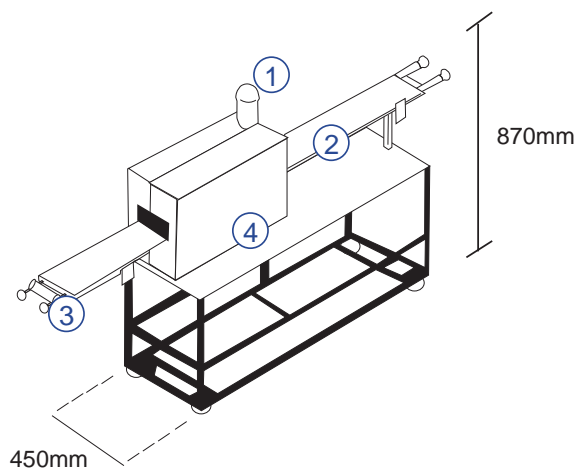

■ Descripciones

1	Deposito de aceite
2	Cinta transportadora
3	Rodillo de cinta
4	Rodillo marcado (interior)
5	Rodillo de doblado
6	Motor
7	Mesón de trabajo (ruedas)
8	Alimentación eléctrica

VISTA FRONTAL

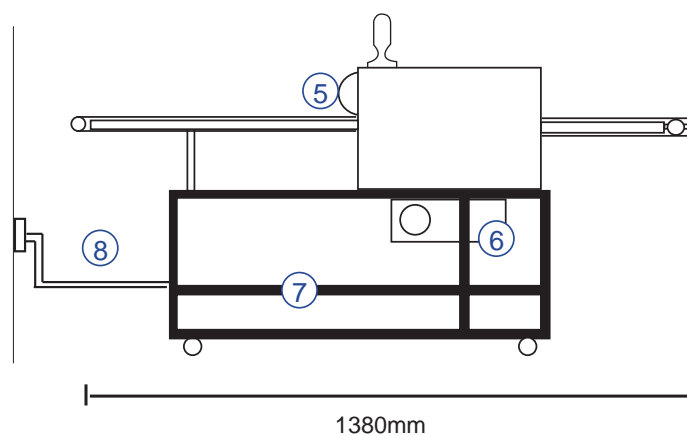

Maquipan Chile S.A.
Av. Don Luis 644 - Parque Industrial Valle Grande
Fono: 747 14 52 - Fax: 747 14 53

www.maquipan.cl